SH12SW

**SEGA CIRCOLARE A LAMA INCLINABILE
CIRCULAR SAW WITH TILTING BLADE
SCIE CIRCULAIRE A LAME INCLINABLE
KREISSÄGE MIT SCHWENKBAREM SÄGEBLATT**

ENGLISH

**USO E MANUTENZIONE
OPERATION AND MAINTENANCE
FONCTIONNEMENT ET ENTRETIEN
BETRIEBS- UND WARTUNGSANLEITUNG**



This handbook gives you all informations required for the correct use of the machine, in this way you avoid damages to production and equipment.

SCM Service is always at your disposal not only for technical assistance but for any problem concerning the development of your business too.

SCM reserves the right to introduce, at any moment without obligation to timely update this Manual, modifications in the components or equipment supplied, as dictated by contingent requirements of a technical or commercial nature.

In addition, the parts added, such as the protections, accessories etc. can differ to conform to the laws and special requirements of the countries to which the machines are to be supplied.

The illustrations and the data contained in this manual are not binding.

INDEX

GENERAL INFORMATIONS

- Machine identification	3
- Mail contact	3
- Safety rules	4
- Technical data	5
- Main optionals	5
- Overall dimensions	6

MACHINE INSTALLATION

- Lifting and unloading machine	8
- Electric connection and grounding	10
- Connection to the centralized suction system	11
- Fitting support frame	11
- Fitting resting rule	13
- Fitting fence for parallel cuts	14
- Fitting saw blade and guard	15
- Fitting scoring blade	19

SETTING UP AND USE

- Control board	22
- Machine start	22
- Saw blade raising and tilting	23
- Scorer use	24
- Scorer adjustment	25
- Guard adjustment	26
- Setting to zero rest rule	27
- Setting to zero fence for parallel cut	29
- Use of fence for parallel cut width up 1500 mm	29
- Use of rolling table and squaring table	30
- Oblique cut on squaring unit	35

MAINTENANCE

- Machine cleaning	38
- Lubrication	39
- Belts tension adjustment	41
- Self-brake motor (optional)	42
- Troubles Causes What to do	44

GENERAL INFORMATION

MACHINE IDENTIFICATION

Model and serial number stamped on the metallic plate applied on machine frame

MACHINE CONTACT

In writing or telephoning to the selling dealer or to SCM on any matter relating to the machine, always include following information:

- Machine model
- Serial number
- Selling dealer
- Detailed description of failure
- Detailed information of particular working to carry out
- Working period number of working hours

SCM S.p.A.
Via Casale, 384
47040 VILLA VERUCCHIO - FO - ITALIA
Tel. 0541-677061 - TLX 550142 -
FAX 0541-677360

GENERAL INFORMATION

SAFETY WARNINGS

1. THIS IS A DANGEROUS MACHINE BE CAREFUL. Only skilled operators should use this machine or be within twenty feet when the machine is in operation
2. Read the Operations Manual carefully before operating.
An Operations Manual should be attached to this machine. It contains important information and warnings concerning the use and operation of this machine. Improper use of this machine may result in serious injuries to persons and fires.
3. Never operate this machine without the safety shields and guards in their proper place.
Operate this machine only when the doors and covers are in their proper protective position.
4. Before attempting oiling, cleaning, adjusting, maintenance or repair, turn off this machine and disconnect this machine from its power source.
Failure to disconnect this machine from its power source could result in electrocution or other injury.
5. Keep all body parts away from the moving parts of this machine, whether it is an operation or at rest.
6. Be certain that this machine is properly grounded before operating it.
7. Do not place hands or fingers between the workpiece and the conveyor belt, near the feed rolls, or near the blades or cutters at any time. Always use a pusher device when undertaking close work.
8. Do not wear gloves or loose clothing (such as sweaters, jackets or jewelry) when operating or standing near an operating machine. Remove any loose clothing and all jewelry when feeding or working near a machine in operation.
9. Do not stand in line with work piece when feeding or unloading this machine
10. Always wear protective eye wear when operating or standing near an operating machine
11. Never overlap or double feed parts; always keep this machine properly adjusted for the work undertaken.
12. Do not run sparking materials (such as steel) with combustible materials (such as aluminium and magnesium dusts); a fire may be the result.
13. Always keep the area around this machine clean and uncluttered. Poor housekeeping could result in slips and falls or other injuries.
14. Concentrate at all times. Failure to pay attention to the task at hand is the cause of most accidents.
15. DO NOT REMOVE THESE WARNINGS. They are permanently affixed to this machine to warn you and all future users of the inherent dangers of this machine.
Removal may result in injuries to you or to others for which you might be responsible.

GENERAL INFORMATION**TECHNICAL DATA**

Fixed table size	645x840 mm
Sliding table size	300x1500 mm
Saw blade tilting	from 90° to 45°
Max. squaring length (with scorer)	1450 mm
Fence for cutting width up to	2600 mm
Cutting width on parallel fence	1000 mm
Saw blade bore	30 mm
Scorer blade bore	20 mm
Max saw blade diameter	300 mm
Max. scorer blade diameter	100 mm
Max. cutting height with blade at 90°	100 mm
Max. cutting height with blade at 45°	70 mm
Saw blade speed	4000 rpm
Scorer blade speed	8000 rpm
Saw/scorer motor	4 Hp
Suction hood diameter	100 mm
Net weight	430 kg
Weight with sea packing	510 kg
Overall dimensions with sea packing	1750x1050x1150 mm

MAIN OPTIONALS

Scorer
 Cutting width on parallel fence up to 1500 mm
 Hung guard
 Disappearing wheels with external control lever
 Single-phase motor: 3 HP (2.2kW)
 Max. available power: 55.5 HP (4kW)

GENERAL INFORMATIONS

OVERALL DIMENSIONS

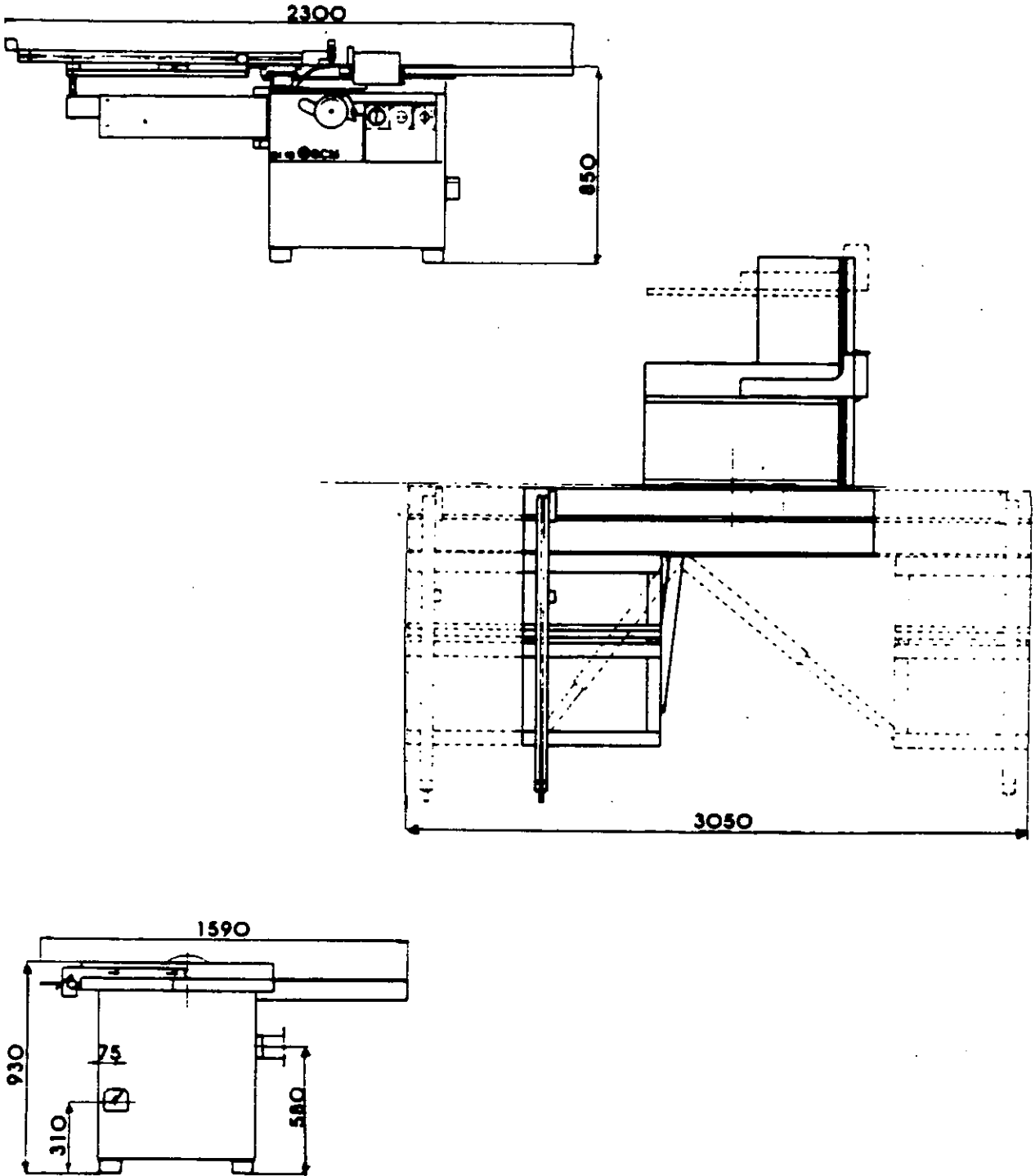

CONTENTS

	Page
Lifting and unloading machine	8
Electric connection and grounding	10
Connection to the suction system	11
Fitting support frame	12
Fitting resting rule	13
Fitting fence for parallel cuts	14
Fitting saw blade and guard	15
Fitting scoring blade	18

INSTALLATION

LIFTING AND UNLOADING MACHINE

Before unloading take off all parts rested on the machine for packing and shipping requirements. Raise the machine using a crane or other lifting device as shown in fig.1: avoid sudden movements.

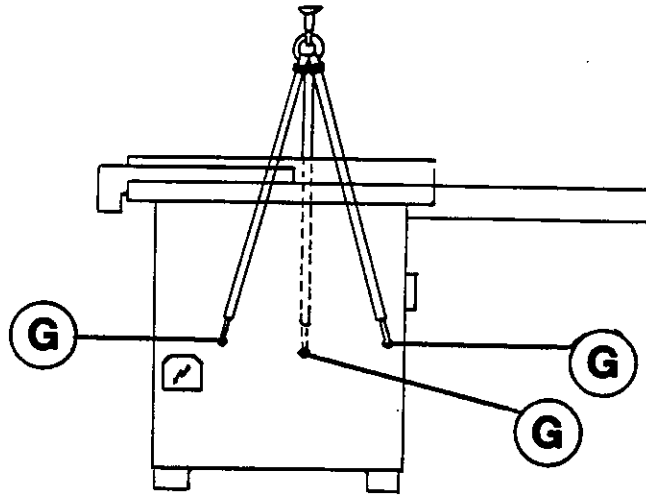
**Fig.1**

If the machine is equipped with socles or pallets it may be raised by a truck inserting the forks under the frame: see figure 2.

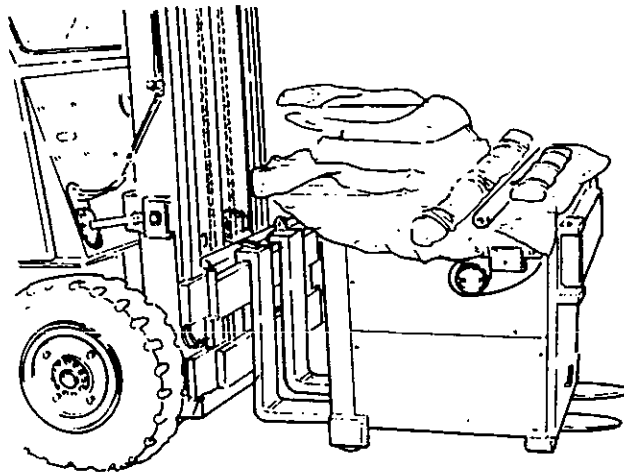
**Fig.2**

If no lifting device is available, let the machine slide on strong boards supported by stands (fig.3): check the machine sliding by ropes stretched by the motor vehicle table.

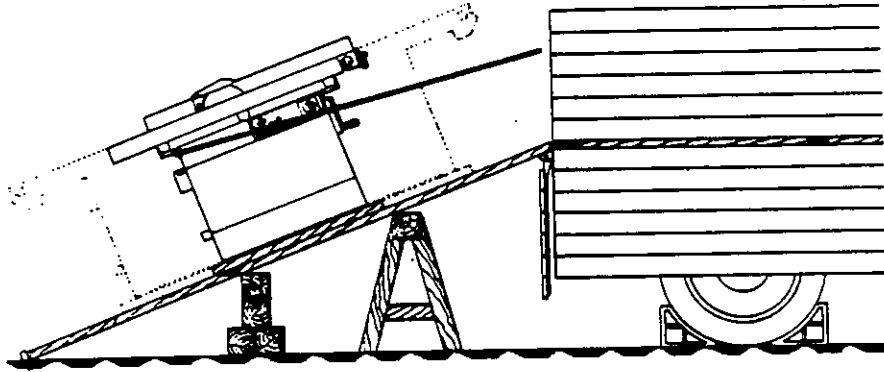

Fig.3

Position the machine after choosing a proper floor made of indeformable material.
Upon request the machine is equipped with disappearing wheels under the frame; to switch on the wheels turn lever (L fig.3A)

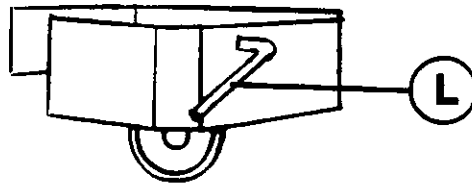

Fig.3A

INSTALLATION

ELECTRIC CONNECTION AND GROUNDING

Before connecting the machine make sure the motor rating agrees with the electric system and the mains voltage corresponds to the machine's one.

Connect the 3 cables to terminals (L1-L2-L3 fig.4), the earth cable (yellow-green) to terminal (PE or fig,4) and the neutral cable to terminal N.

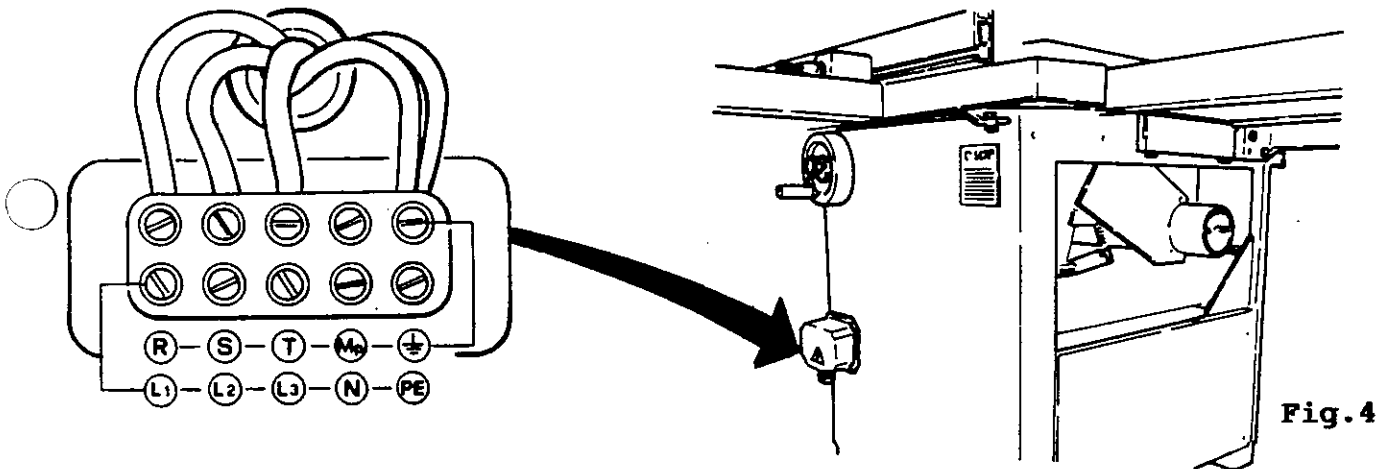

Check the direction of spindle rotation: the saw blade shall rotate in the direction opposite the workpiece feed: for this purpose start the machine as indicated on page 22.
If the saw blade rotation is not right:

- 1) Cut out the voltage
- 2) Reverse two phases in the terminal board

CONNECTION TO THE SUCTION SYSTEM

External diameter of exhaust hood: 100 mm (fig.5)

Connect the hood to the system by means of a hose with proper diameter.

The suction system requires a flow equal to 900 m³/h at a flow speed at least 25 m/s.

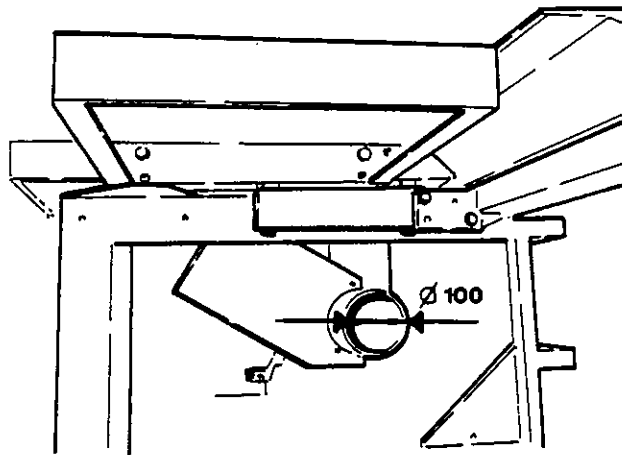

Fig.5

FITTING SUPPORTING FRAME

- 1) Rest supporting frame on the rolling table into the proper groove
- 2) Fit pivot (S fig.7) into pivoting arm end and rest the frame on it.
- 3) Lock the frame by knobs (P fig.6)

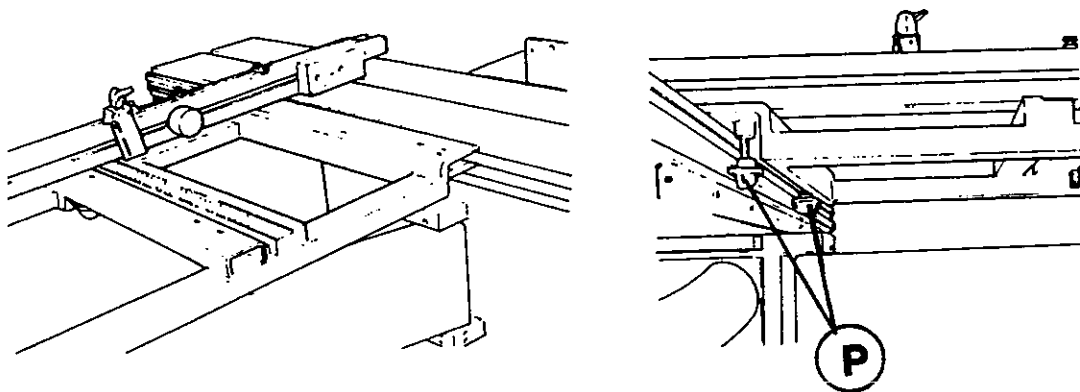

Fig.6

INSTALLATION

FITTING SUPPORTING FRAME

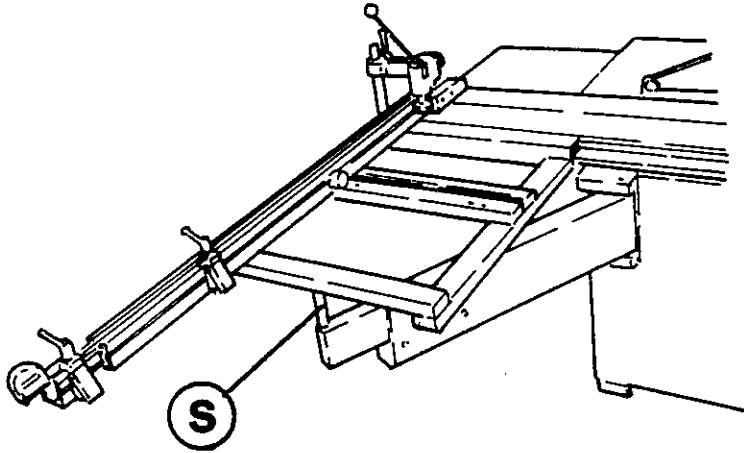

Fig.7

FITTING RESTING RULE

- 1) Insert pivots (P and P₁) into holes (F and F₁)
- 2) Lock the fence on the table by inserting the 2 knobs (S) into the bottom table part, then screw the knobs into the inside threading of pivots (P and P₁ fig.8)
- 3) Fit stops (G and G₁ fig.9)

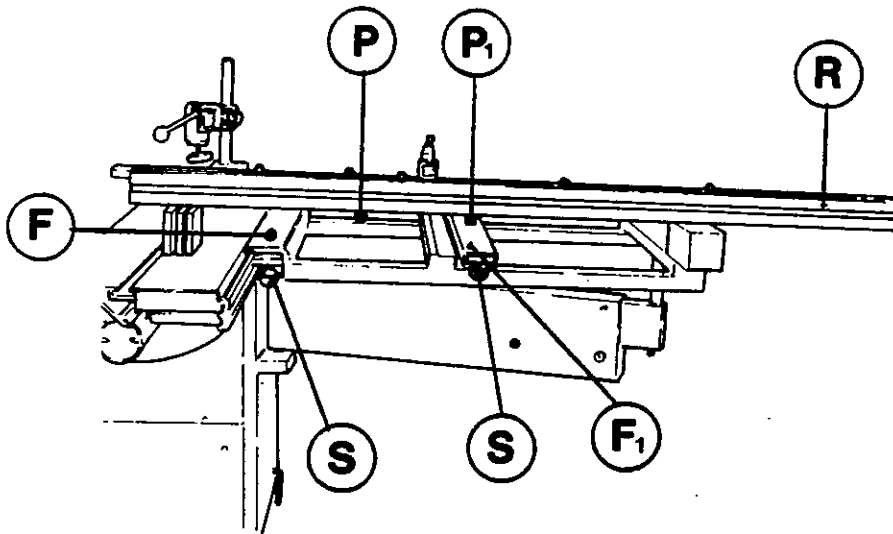

Fig.8

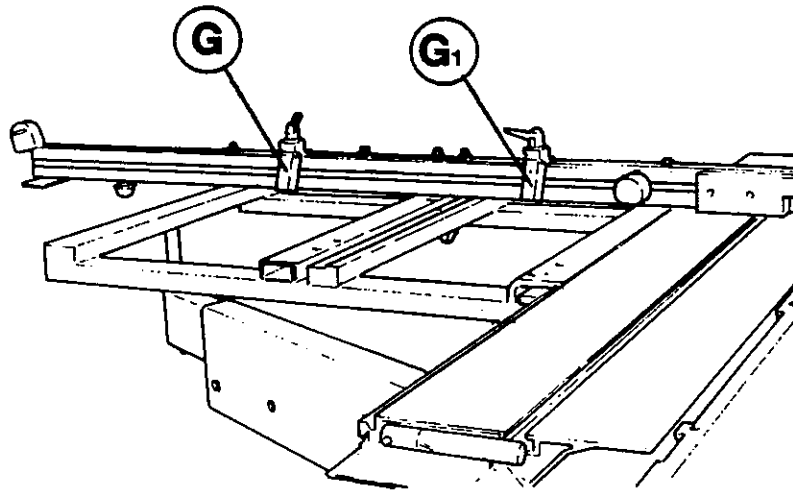

Fig.9

INSTALLATION

FITTING FENCE FOR PARALLEL CUTS

Fasten rod (D fig. 10) to holes (S) of the table and of the rear additional table by means of the 4 screws (V).
Fasten rear table (P) so that its surface is aligned with the worktable.

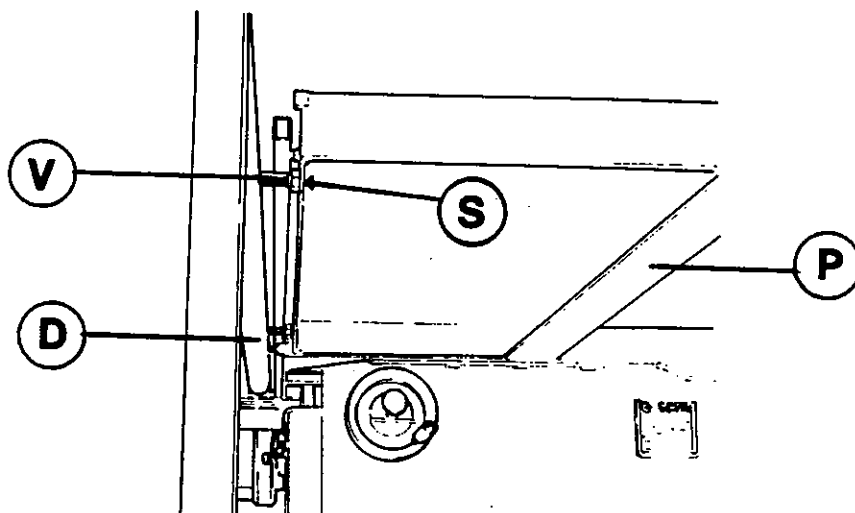

Fig.10

- Fit support (S) to rod (D fig.11)
- Fit fence (G), adjust the length, then fasten it by two grips (M)

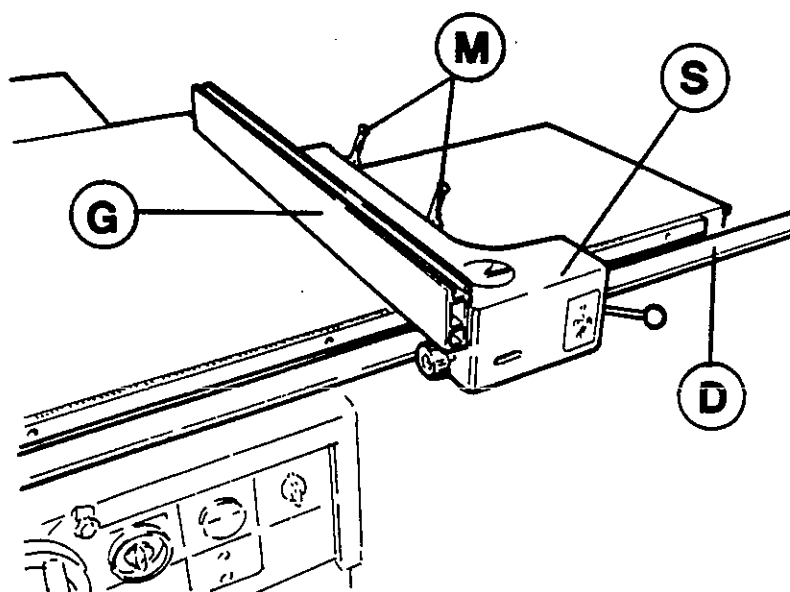

Fig.11

FITTING SAW BLADE AND GUARD

To fit or to replace the saw blade lift saw spindle to extreme position by handwheel (V fig.12)

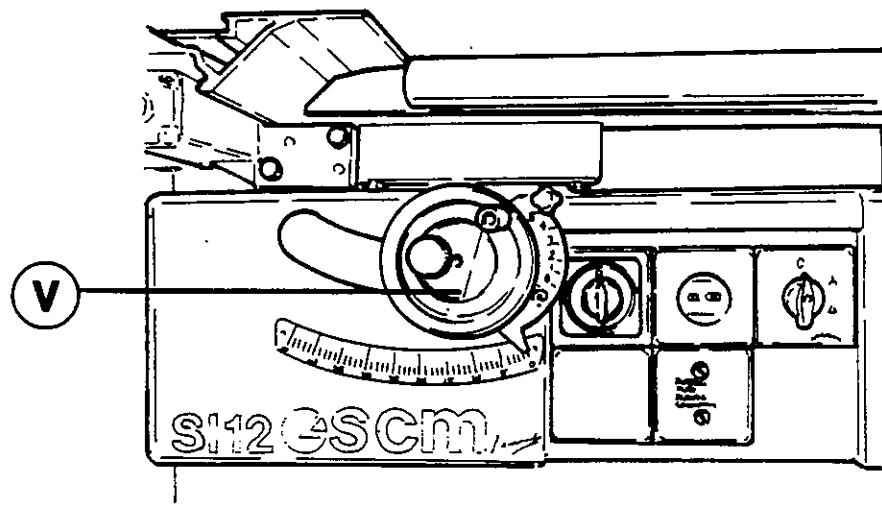

Fig.12

Fit pivot (A fig.13) into the table hole and turn spindle in order to lock it.
The screw which tightens the saw blade is lefthand that is turn it clockwise to unscrew it.

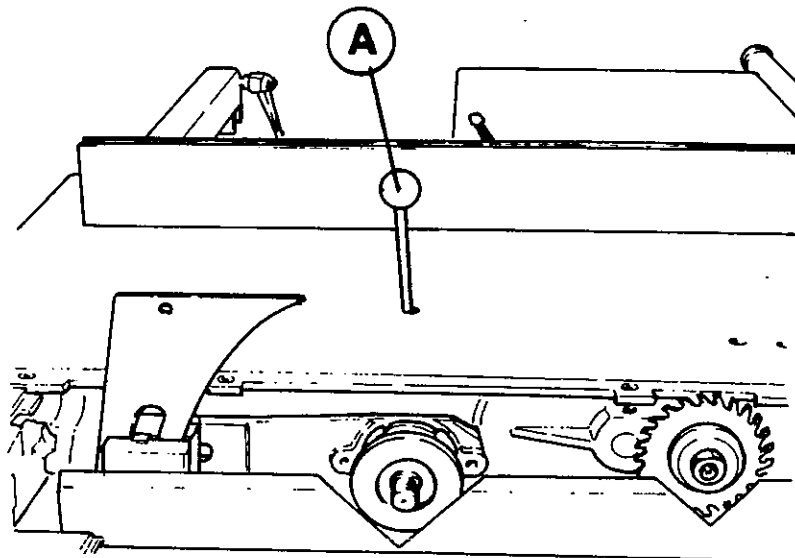

Fig.13

INSTALLATION

Unscrew nut (E fig.14), and one flange (F).
Before fitting the saw blade check that both flanges (F) are clean.

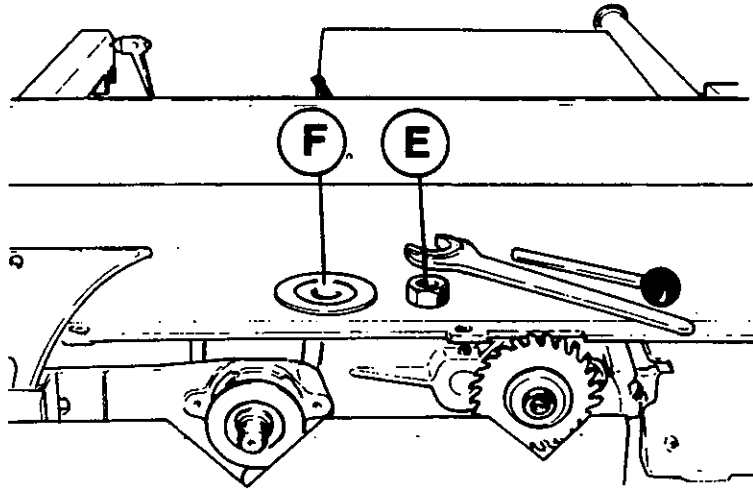

Fig.14

Fit pivot (A) again and tighten nut as shown in fig.15.

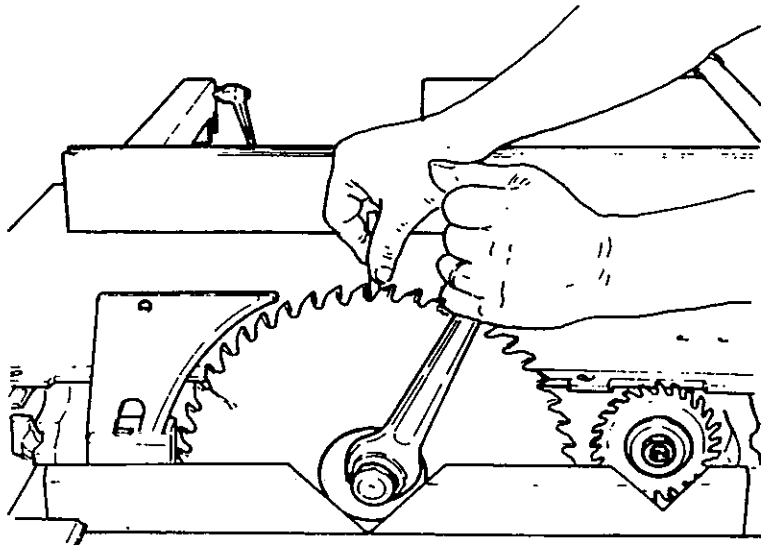

Fig.15

After fitting the blade, apply on the riving hood (A fig.16) and bottom cover (C).

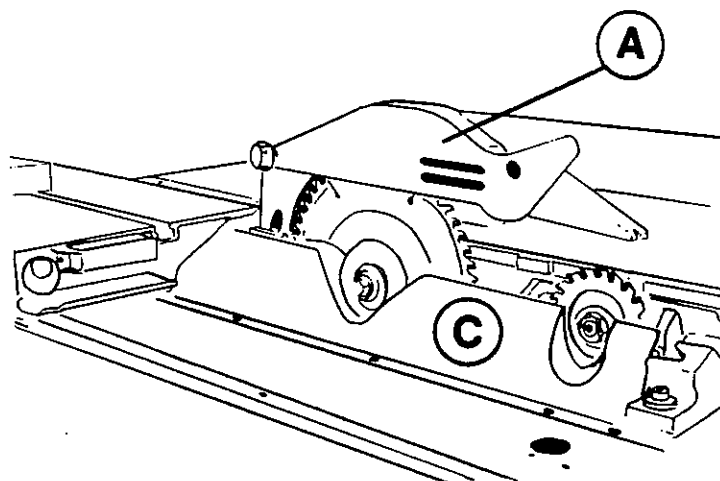

Fig.16

Fig.17 shows another guard type

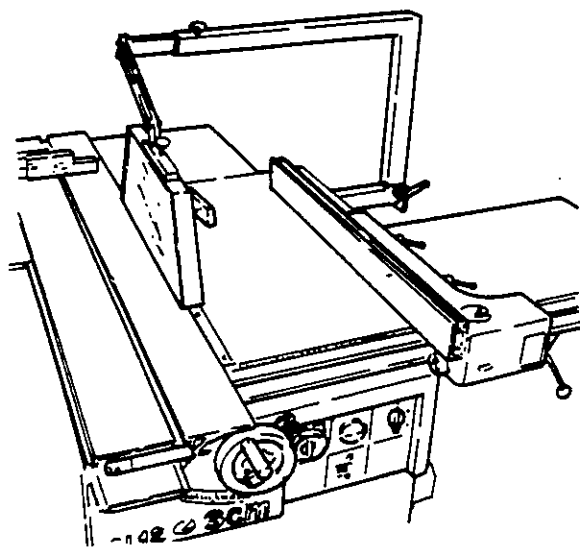

Fig.17

NOTE: The riving knife with a 3 mm thickness fits well in the case of blade with 3.5 mm thickness.
If you use blades of different thickness, you have to replace the riving knife.

INSTALLATION**FITTING SCORER BLADE**

- Lock spindle by fitting 8 mm wrench (E fig.18) into hexagonal groove
- Loosen nut (H) with right handed thread

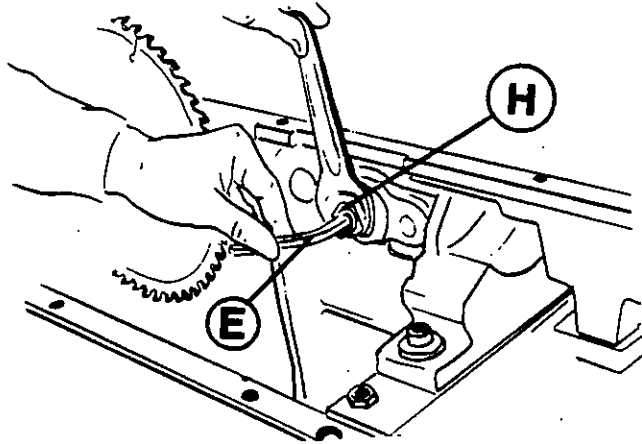

Fig.18

Remove nut (H fig.19) and one flange (F), check that both flanges (F) and scorer blade are clean.

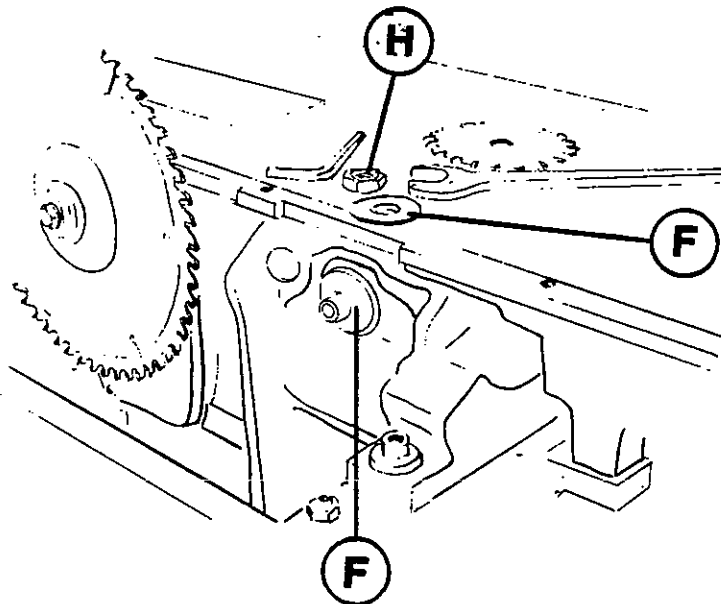
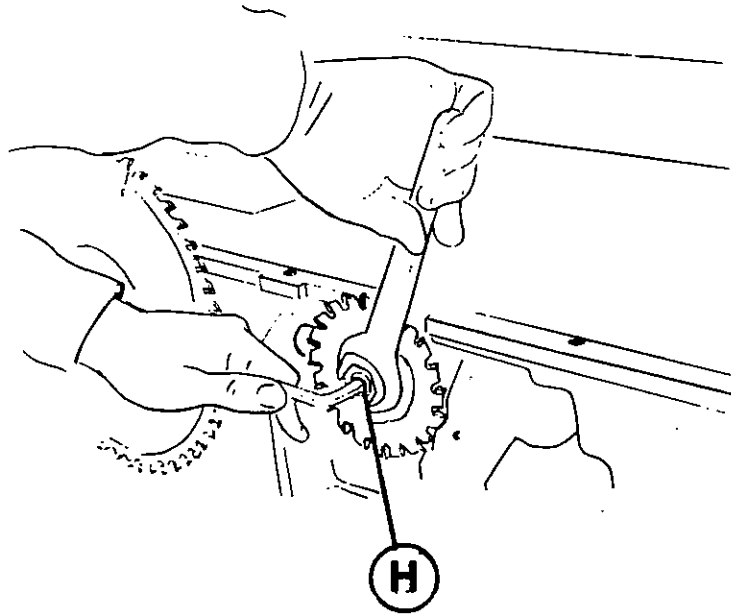

Fig.19

INSTALLATION

Fit the blade, the flange and the nut, then after locking the spindle as described previously tighten nut (H fig.20)

**Fig.20**

SETTING UP AND USE

CONTROL BOARD

It depends on the machine version as well as the regulations of the different countries.

- A- Padlockable main switch
- B- O-Y- change over switch for starting the saw blade
- C- Push buttons I-O of thermomagnetic protection (scorer motor)
- D- Access to fuses housing

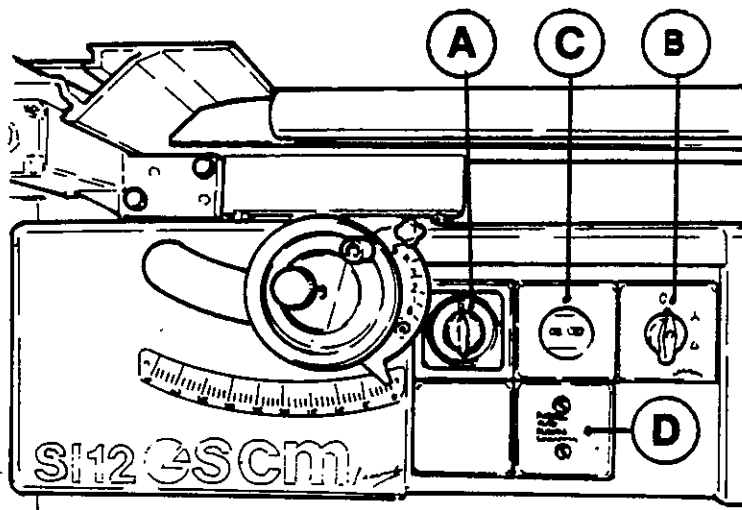

Fig.21

MACHINE START

- 1) Turn main switch (A) to position 1
- 2) Turn change-over switch (B) to position Y until the spindle reaches the right speed, then turn selector to position
- 4) Press button I of thermomagnetic protection (C) to start the scorer

CONTENTS

	Page
Control board	22
Machine start	22
Lifting and tilting blade	23
Scorer use	24
Scorer adjustment	25
Guard adjustment	26
Setting to zero the rest rule	27
Setting to zero the fence for parallel cuts	29
Fence use	29
Use of rolling table and squaring table	30
Oblique cut on squaring unit	35

SETTING UP AND USE

SCORER USE

If both edges of the panel are to be finished, you have to use one of the following tools:

- 1) Scoring blade with the thickness equal to the saw blade's one (fig.24)
 - 2) Double cutter by inserting shims between the two elements (fig.25)
 - 3) Conic scoring blade which enables the alignment with blades of different thickness or to obtain on the two edges of the panel two chamfers (fig.26)
- If the panels are very long and not perfectly straight the chamfers may be not uniform.

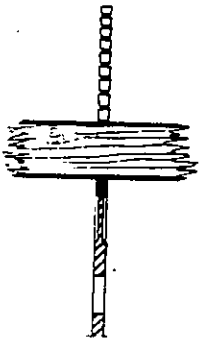

Fig.24

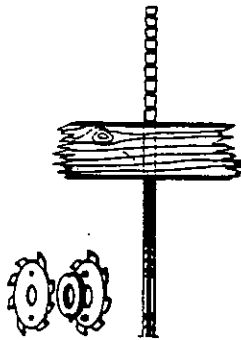

Fig.25

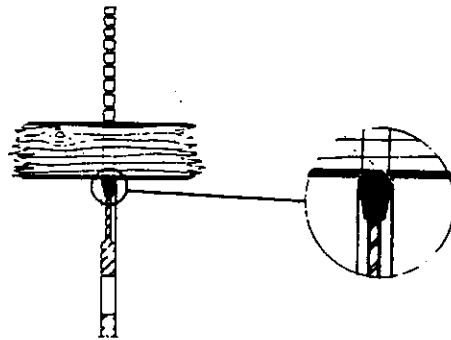

Fig.26

LIFTING AND TILTING THE SAW BLADE

Turn handwheel (V) clockwise to raise the blade: the saw blade height is right when it exceeds the workpiece thickness 1-1.5 cm. After the adjustment, lock handwheel (V) by knob (G fig.22)

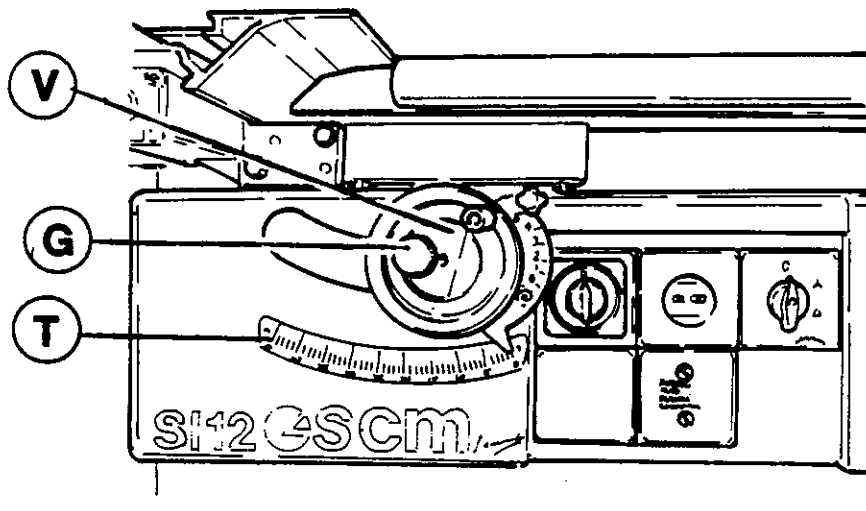

Fig.22

By means of handwheel (L) the blade may be tilted up to 45°: a complete turn corresponds to a 2° tilting. Read the tilting angle on plate (T), then lock with knob (P fig.23).

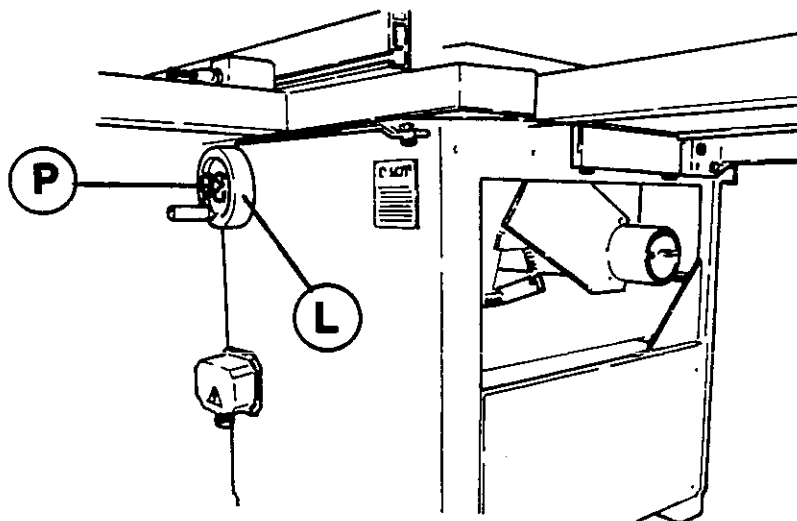
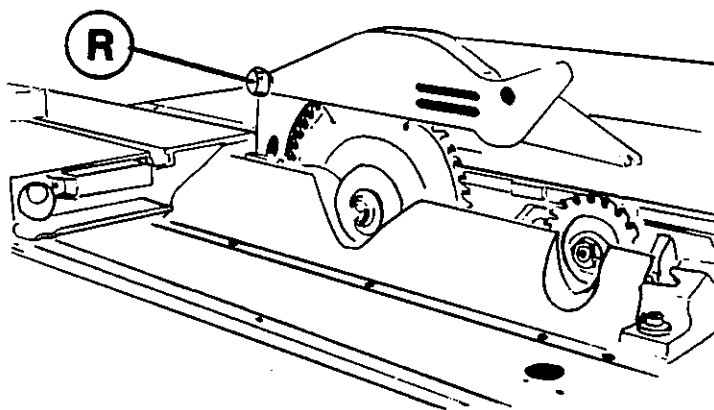

Fig.23

SETTING UP AND USE

GUARD ADJUSTMENT

Guard (fig.29) is fitted to riving knife by means of knob (R). Never take off the guard and position it so that the saw blade is completely covered.

**Fig.29**

The machine may be equipped with a special guard (fig.30)

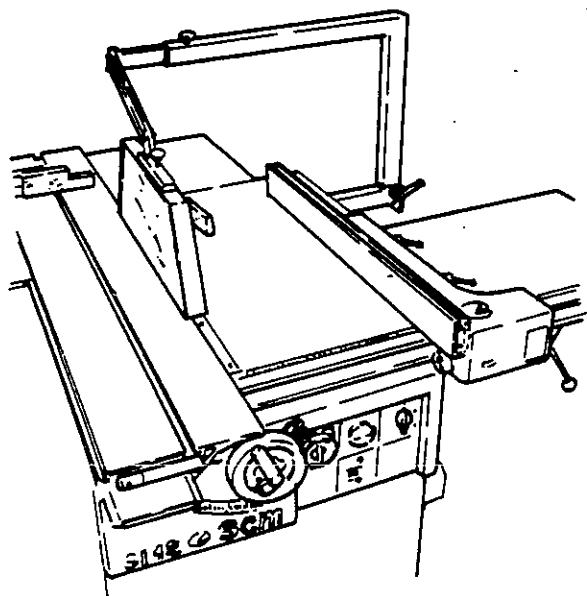
**Fig.30**

SCORER ADJUSTMENT

- Loosen knob (P fig.27)
- Turn it along the graduated sector and lock it at the measure required
- The range for scorer height adjustment is 0-5 mm over the table

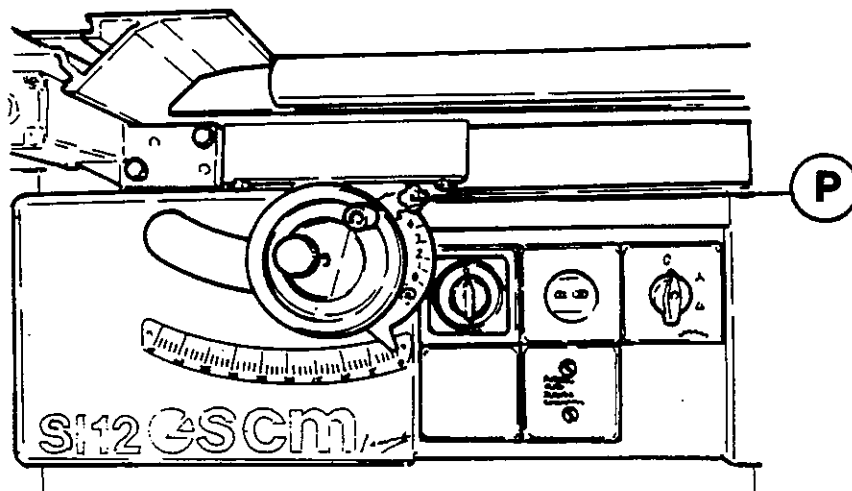

Fig.27

- For aligning the scorer with the saw blade proceed as follows:
- fit the 6 mm wrench (supplied with the machine) into hole (F fig.28)
 - then turn clockwise or counterclockwise until the scorer is aligned with the saw blade

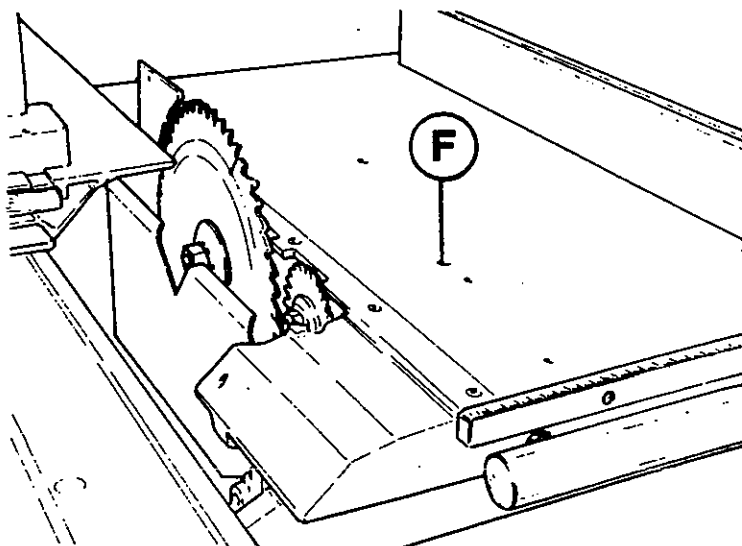

Fig.28

SETTING UP AND USE

- Trim a panel so that the sides are perfectly perpendicular each to other
- Lock stop (A) on the rule in any position
- Carry out a cut: one trimmed side of the panel is against the rule, the other against stop (A)
- Read the cutting measure (L)

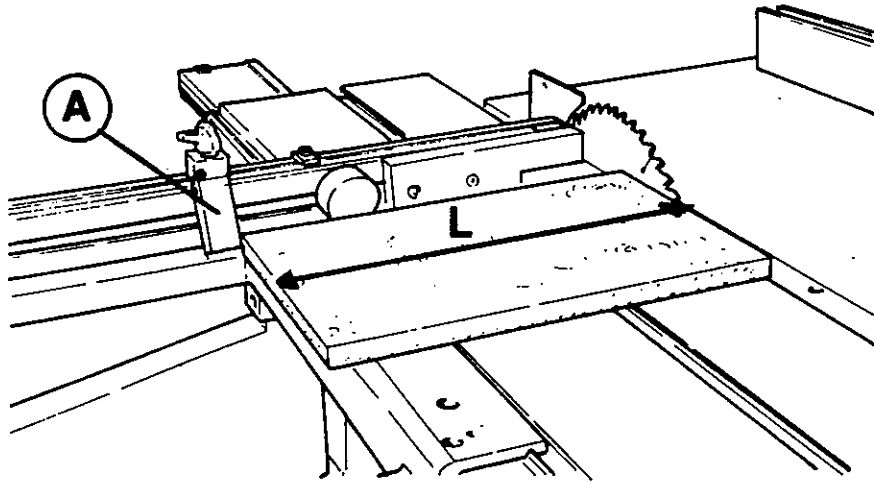

Fig.32

- Leave the position of stop (A fig.32) fixed
- Loosen millimetric rule (M fig.33) by turning knob (F)
- By using the pointer or the lens of stop (A fig.32) move rule (M) until the line corresponding to measure (L fig.32) obtained by cutting the panel coincides with the reference line of the lens of stop (A).
- By means of knob (F fig.33) lock rule (M): the setting to zero has been carried out

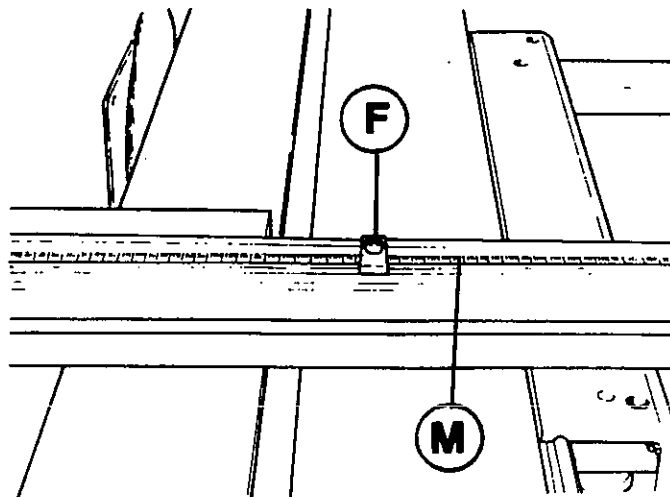

Fig.33

SETTING TO ZERO THE REST RULE

- Lock stop (A fig.31) on the rule by knob (P) in any position (f.e 25 mm)
- Rest a mason's rule against a saw tooth and move the rest rule so that the distance from the left side of stop (B) to saw blade is equal to the value selected (i.e 25 mm).
- Lock the rest rule on the squaring table by knobs (S fig.31a)

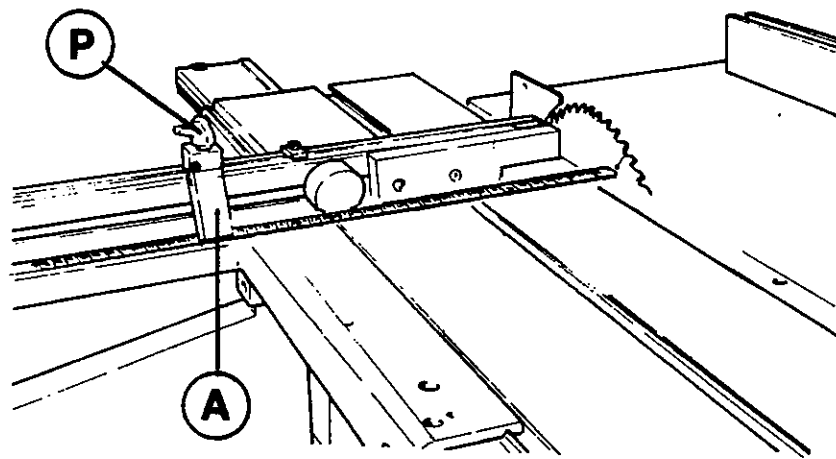

Fig.31

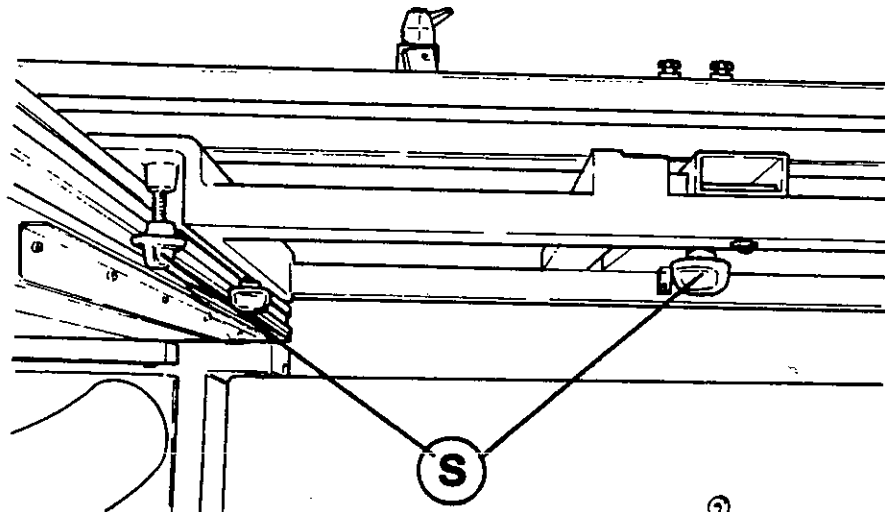

Fig.31a

SETTING TO ZERO THE FENCE FOR PARALLEL CUTS

It is carried out during the machine test at factory

USE OF FENCE FOR PARALLEL CUT WIDTH UP TO 1500 mm

The aluminium fence (A) may be moved and locked by knobs (P): two positions are possible:

- 1) Horizontal position (O) to cut thin workpieces
in this case you shall use a push block
- 2) Vertical position (V) for longitudinal cuts
For traverse cuts by using the fence as a length stop position
it longitudinally so that its outlet end is at the height of
the saw blade center

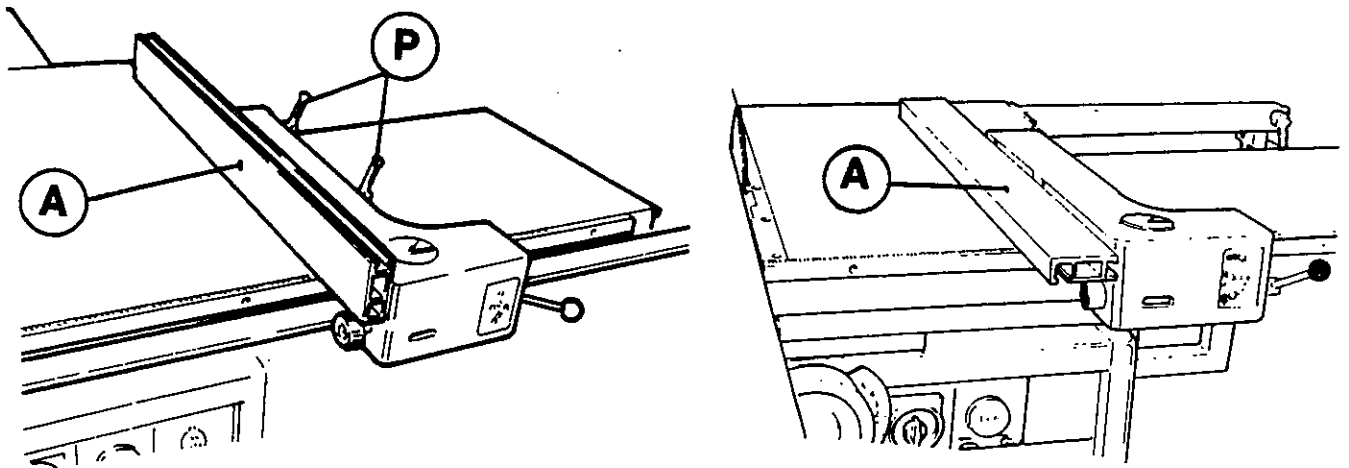

Position "V"

Fig. 34

Position "O"

SETTING UP AND USE

USE OF THE ROLLING TABLE AND SQUARING TABLE

Example for carrying out the squaring:

- Carry out the first longitudinal cut by resting the panel against the stop (L) and fastening it by clamp (S)

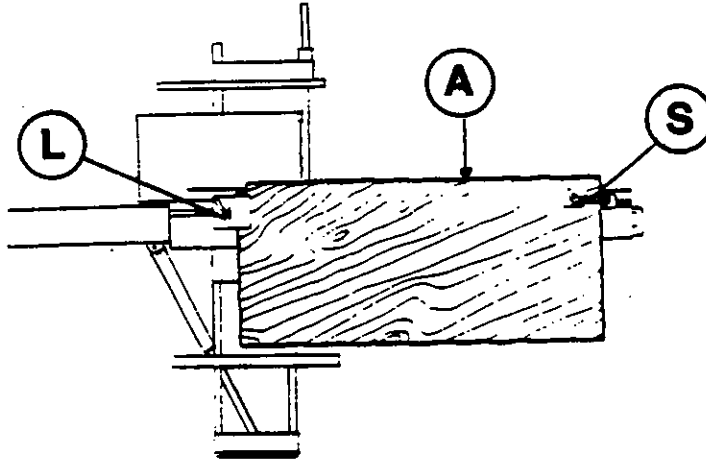

Fig. 35

- Turn panel 90° so that the trimmed side (A fig.42) rests against the aluminium fence, then carry out cut (E).
- Turn panel 90° and rest side (F fig.37) you have now trimmed against the aluminium fence and side (A) against stop (T) positioned according to cutting measure, then carry out cut (C)
- Turn panel 90° again: rest side (C fig.38) against aluminium fence and side (B) against stop (T) set according to cutting measure, then carry out cut (D).

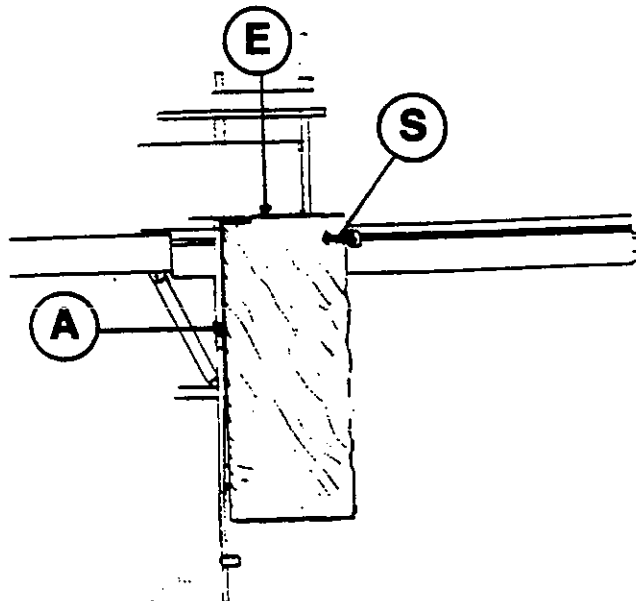

Fig. 36

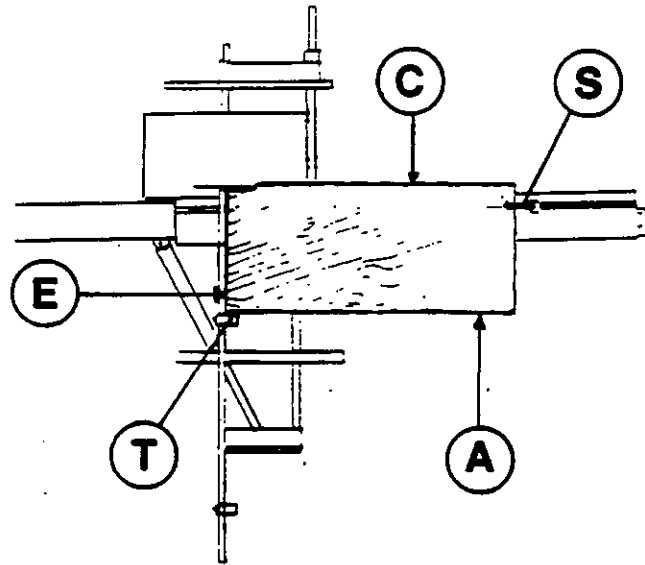

Fig. 37

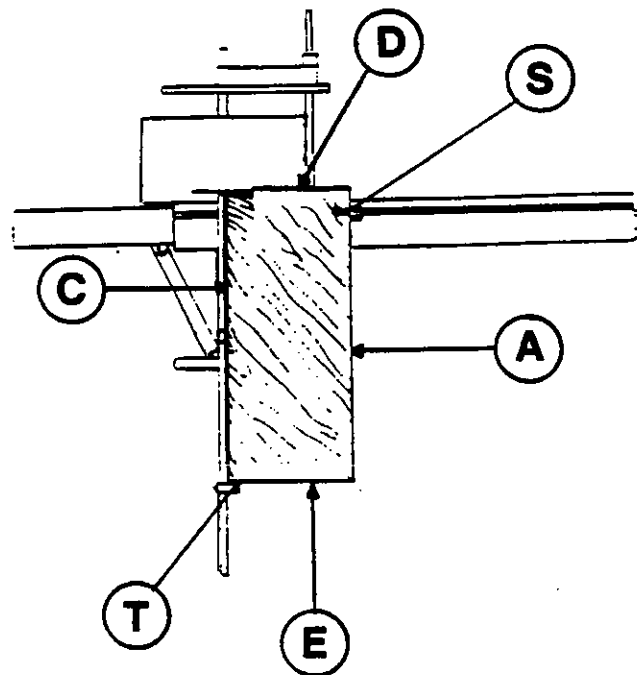
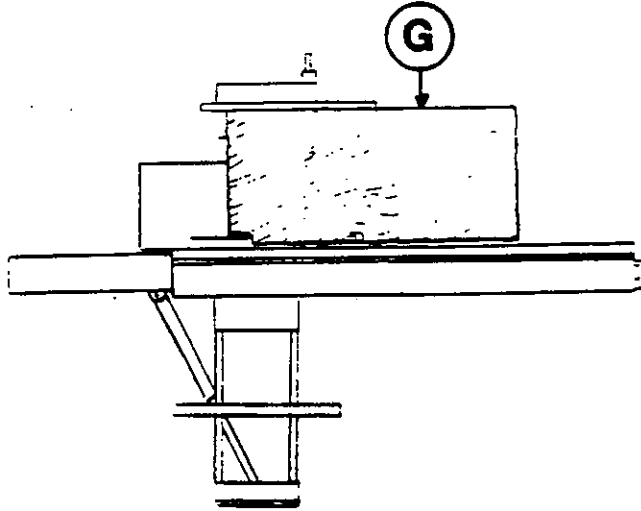

Fig. 38

SETTING UP AND USE

Another system to carry out the squaring is the following:

- Carry out the trimming cut as previously described
- Rest side (G) you have now trimmed against aluminium fence positioned according to the measure required, then cut.

**Fig.39**

The first cutting-off is carried out by resting the panel against the fence

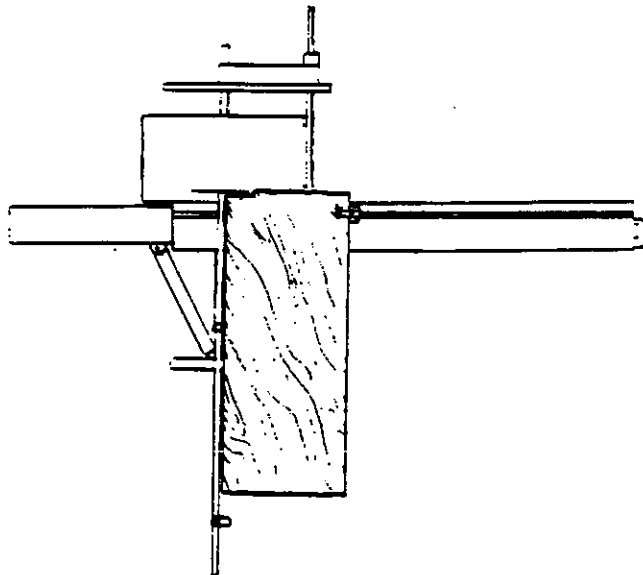
**Fig.40**

Now cut-off by resting the panel always against the aluminium fence but by using stop (F)

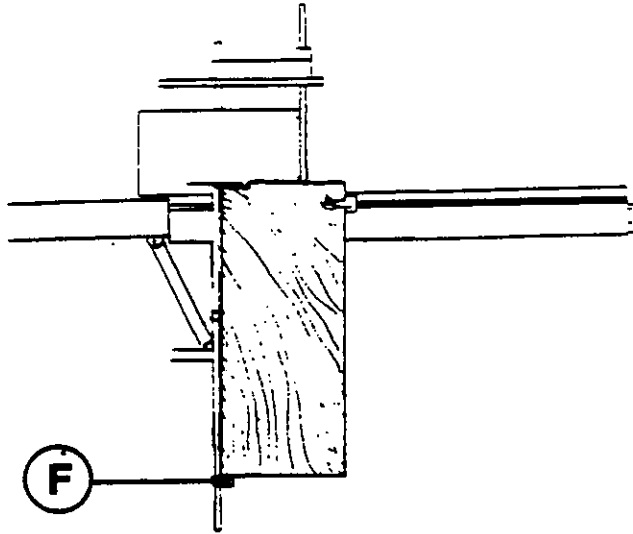
**Fig.41**

For the entire stroke of the rolling table loosen the table and move it along the rolling table (when this one is at the end of stroke); lock the frame by knob (P), then move the rolling table: total stroke.

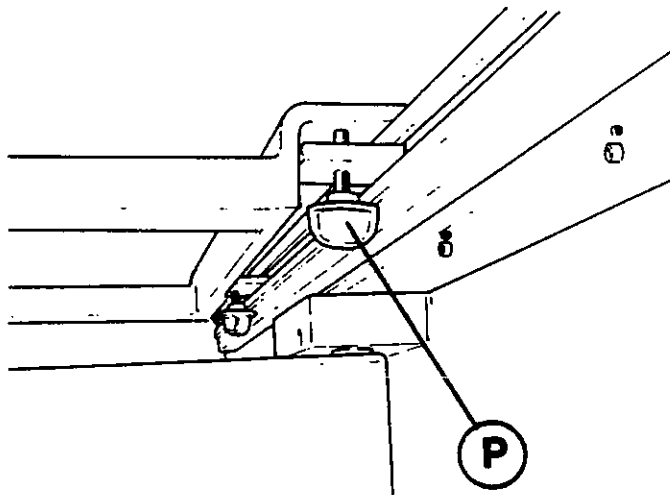
**Fig.42**

It is advisable to work with the fence following the workpiece only in case of small pieces

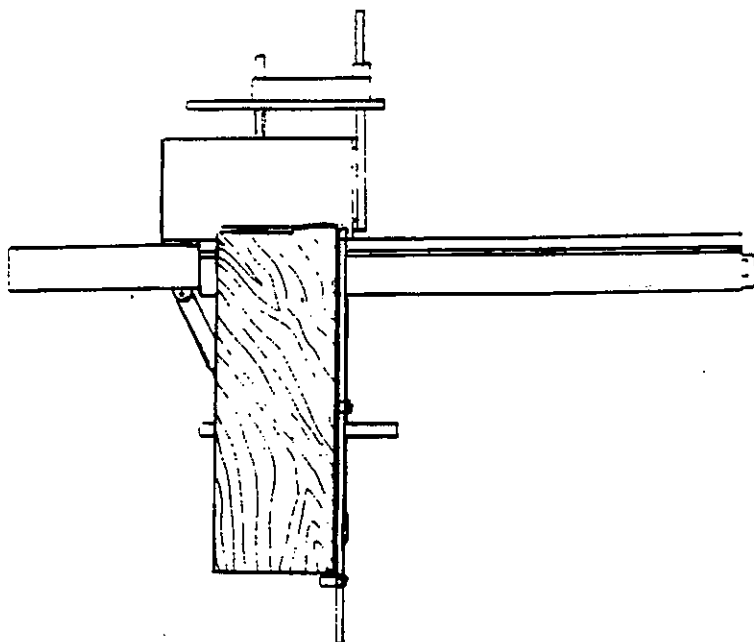

Fig.43

SETTING UP AND USE

OBLIQUE CUT ON SQUARING TABLE

You have to use rule (M) with two end holes corresponding to 0° and 45° angles
 Fit pivot of fence (G) into hole (A) and the other pivot into the hole corresponding to 45° angle (fig.44)

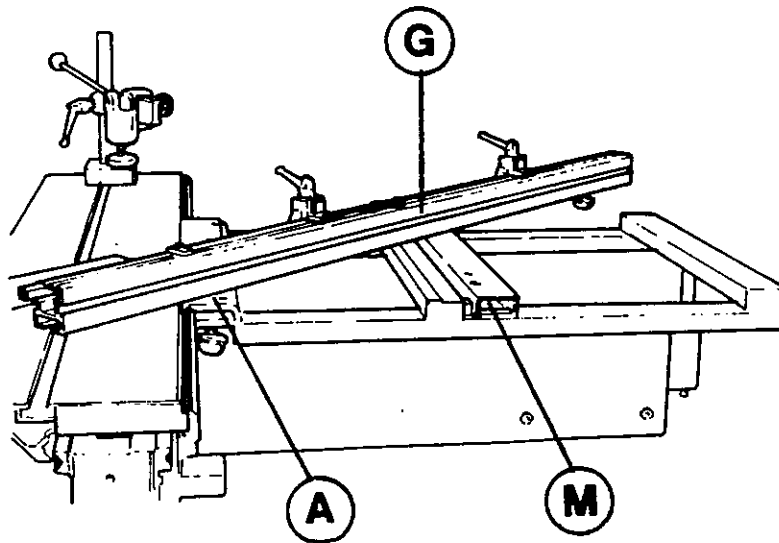

Fig.44

To obtain intermediate positions fit pivot of fence (G fig.45) into hole (A) then fit the other pivot into slot (F); now set the fence in the right position reading the angle on the proper plate.
 Lock fence (G) by means of knobs.

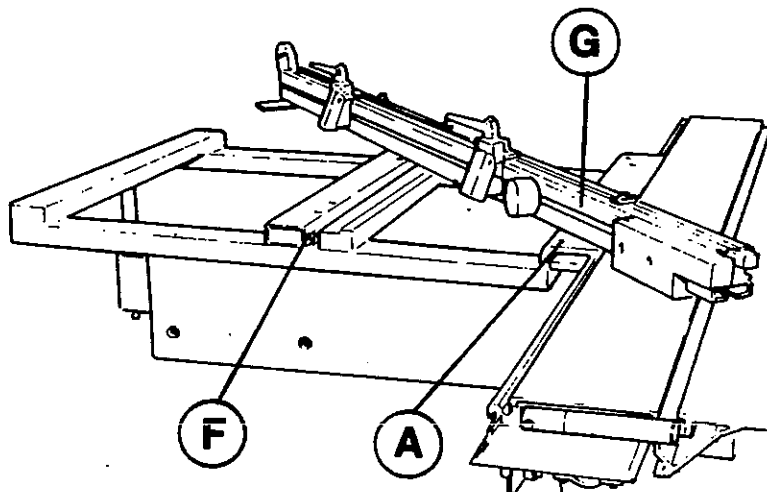

Fig.45

CONTENTS

	page
Machine cleaning	38
Lubrication	39
Belt tension adjustment	41
Self-brake motor (upon request)	42
Troubles-causes-what to do	44

MAINTENANCE

MACHINE CLEANING

An accurate cleaning of the machine ensures longer machine life and it is an important safety precaution.

- 1) Make sure that inside the motor housing there are no chips
- 2) Every week clean all moving parts especially those which are subject to resin and dust using turpentine or proper solvent.
- 3) Take particularly care of: slideways, the rod of fence and the groove where the squares and presser slide.

IMPORTANT

Periodically clean the rolling table slideways with naphta or other solvent.

LUBRICATION

Every week grease:

- 1) Screws (V fig.46) as well as sectors (S)
- 2) Sleeves (C) and rods (A) of the scoring unit with a light grease film after cleaning them with a jet of compressed air.

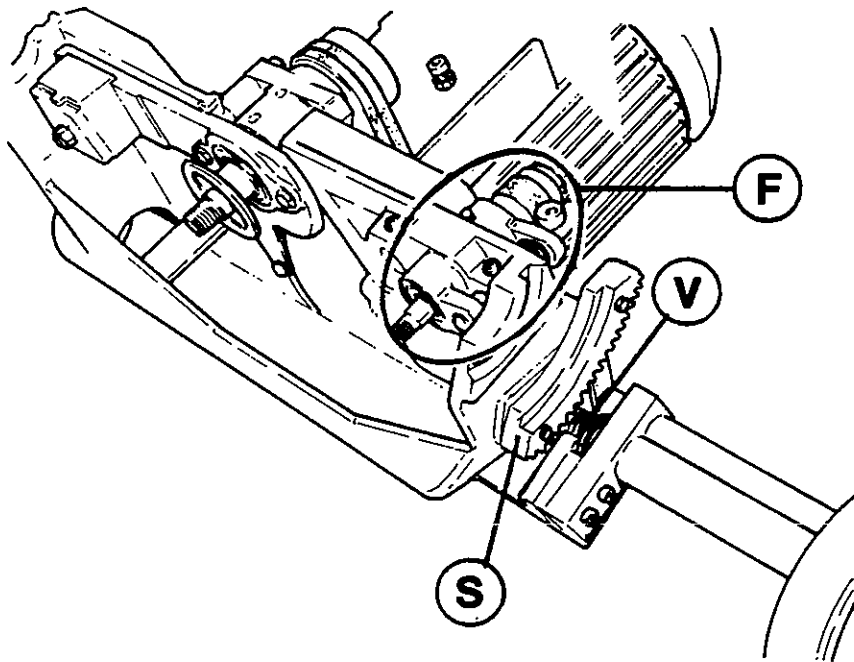
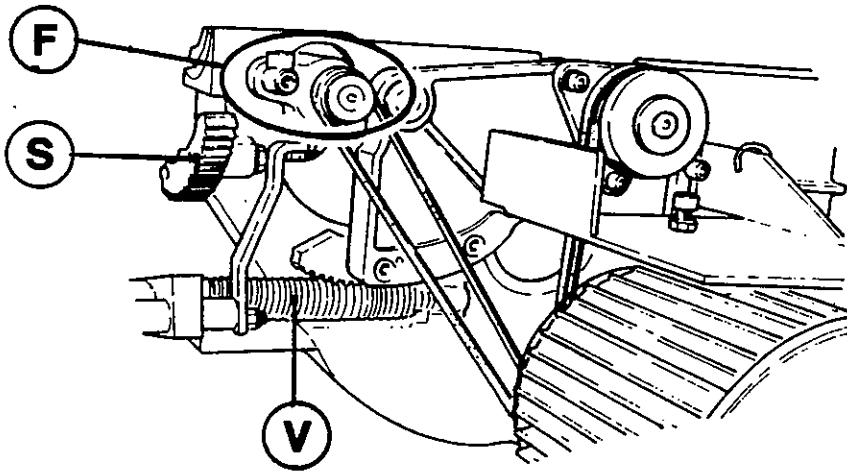

Fig.46

MAINTENANCE

Every week oil:

- 1) Slideways (A fig.47) for saw blade tilting
- 2) Surfaces (B) and pivot (C) for saw blade lifting
- 3) Joints (D fig.47) of riving knife

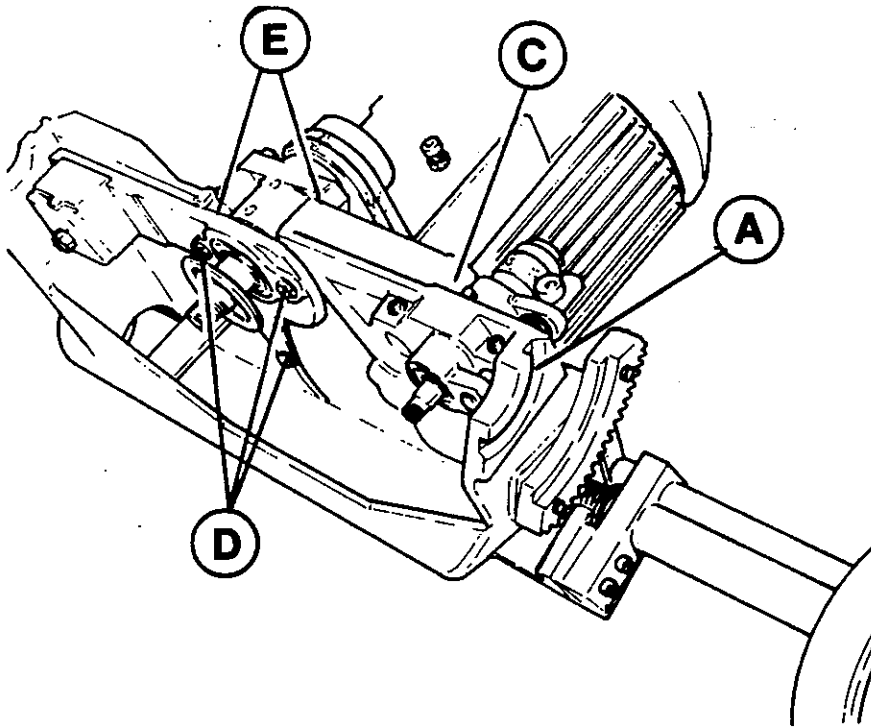

Fig.47

IMPORTANT

All bearings are lubricated for life and proof: therefore they don't require any lubrication.

BELTS TENSION ADJUSTMENT

To increase the belts tension loosen the four nuts (D fig.48) and nut (E); then screw down screw (V), tighten nut (E). The belt tension is right when applying a force (approx. 3 kg) you get an elastic deflection of 5 mm

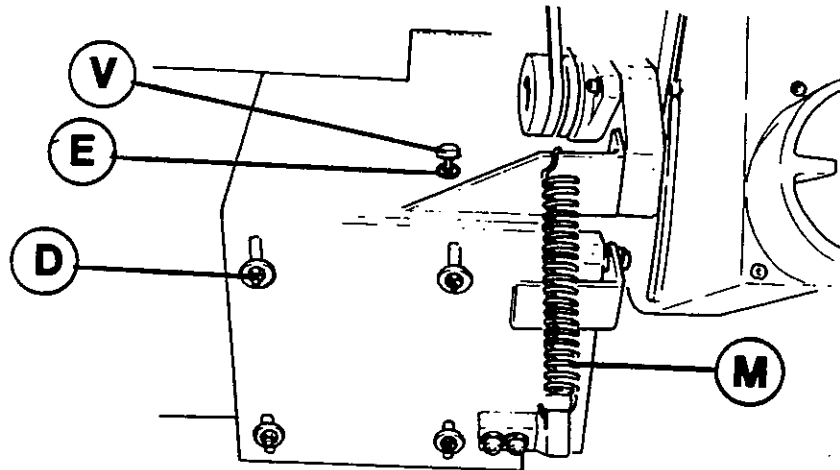

Fig.48

The belt of the scorer unit is always stretched by spring (M fig.48)

- 1) Use V-Belt 3V 250 9.5X8 length 635 for 50 Hz and 60 Hz motor, code number: SCM 0000603361F
- 2) Flat belt for the scorer 1165x20 MEGADYNE TIPO 150 code number: SCM 0000604039D

MAINTENANCE

SELF BRAKING MOTOR (UPON REQUEST)

To carry out the working turn selector (G fig.49) to the left. When you turn the switch for saw control to position 0, the motor automatically brakes. For changing blade the spindle must rotate freely; in this case turn selector (G) to the right; pilot lamp (H) lights up. The motor may be started only if selector (G) is turned to the left.

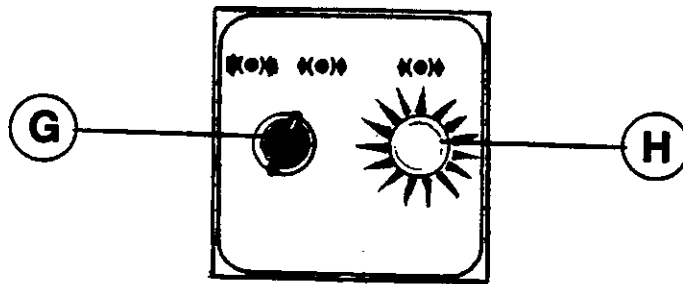

Fig.49

Periodically check and if necessary adjust the braking electromagnetic device (See fig.50)

CUT OUT MACHINE BY TURNING MAIN SWITCH TO POSITION 0 WHEN MAKING ADJUSTMENTS.

Electromagnet brake clearance

Distance (A fig.50) between electromagnet (B) and mobile core (C) is called "air gap" and is adjusted during device construction. Adjustment is required only in case of replacement of mobile core (C) having glued to its surface a brake disk of friction material being subject to wear (F).

Wear limit of friction disk is 3 mm.

Replacement must be carried out only by technician of your local dealer.

Adjustment of braking unit

Braking efficacy reduction can be noticed by increasing of time required to completely stop spindle.

Best braking torque is obtained as follows:

- remove protection cover (P)
- insert an Allen wrench into seat (G) foreseen at spindle end, thus avoiding rotation of same.
- screw progressively nut (D) till joining mobile elements and eliminating distance (A) (brake clearance)
- unscrew nut (D) of half a turn
- fit protection cover
- start and stop motor a few times to check correct running.

NOTE

Mechanical brake release is obtained withdrawing nut (D) more than 1 mm.

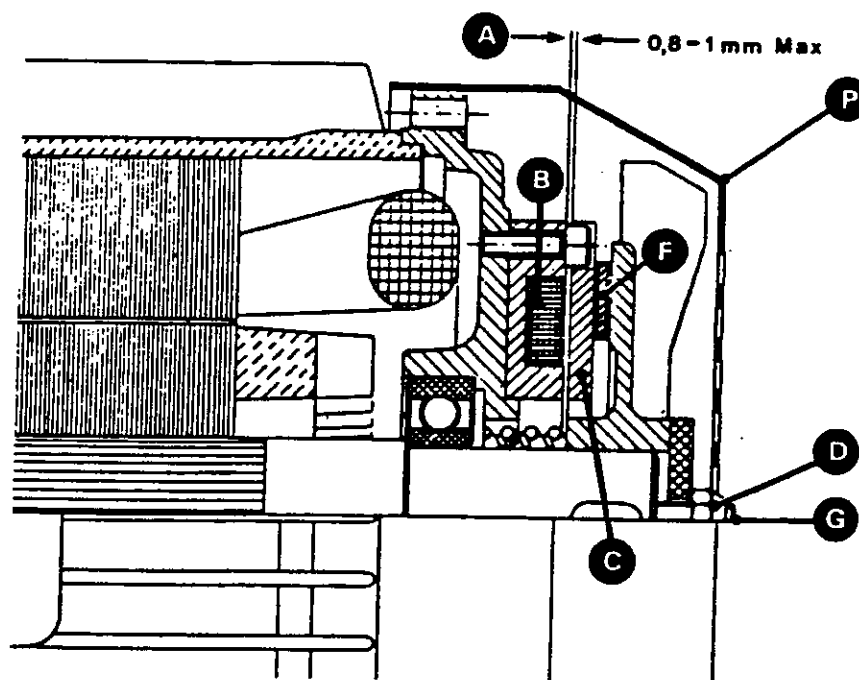

Fig.50

MAINTENANCE

TROUBLE	CAUSE	WHAT TO DO
The machine does not start	Lack of power supply on one phase or more phases	Make sure that all three phases receive power supply
	Start switches disconnected	Make sure that the switches receive power supply Replace switches
	Thermal cut-out disconnected	Reset the thermal cut-out
	Door for motor access open	Shut door so that it is in contact with microswitch
	Emergency button on	Switch off the button by turning it
	Fuses of the auxiliary circuits switched off; or caps of fuses loose	Tighten caps; if the machine does not start 1- unscrew caps 2- check fuses, if necessary replace them
Main switch in position 0	Turn switch to position 1	

MAINTENANCE

TROUBLES	CAUSE	WHAT TO DO
The machine stops during the working	Lack of power supply on one phase or more phases	Make sure that all phases receive current
	Fuses of auxiliary circuit switched off or caps of fuses loose	Tighten caps; if the machine does not start 1- unscrew caps 2- check fuses, if necessary replace them
	Excessive electrical input due to many hours of continuous working	Await until the thermal cutout on control board is cold Switch it on after some minutes.
	Too heavy work for the motor power	Reset the thermal cutout and machine only pieces which don't require higher motor power
The motor rotates but the saw blade stops when it is in contact with the workpiece	Belts between motor pulley and saw pulley are slack	Stretch belts as described at page 38
The cut measure on panel does not correspond to the measure read on the rest rule	The rest rule has moved	Set rule to zero as described at page 27
	The millimeter rule has moved	

MAINTENANCE

TROUBLES	CAUSE	WHAT TO DO
The cut measure on panel does not correspond to the measure read on the pointer of the fence for parallel cut	The pointer has moved	Set the fence to zero see page 29
The saw blade "rubs" the panel after the cut	Fence position to saw blade not right	<p>With the machine standstill rest the aluminium fence against the saw blade if the saw teeth rest on the fence before and behind, or only behind, you have to adjust the parallel fence:</p> <ol style="list-style-type: none"> 1) loosen the screws which lock the supports of the toothed round rod 2) turn the unit steps by steps until the aluminium fence touches only the front teeth: that is a 0.10 mm clearance between the aluminium fence and the rear teeth 3) Lock the table supports and carry out a test cut
The cut is not parallel	Fence not well adjusted	<p>The fence shall be parallel to saw blade it is required a 0.10 mm clearance at the outlet side. To adjust the parallelism proceed as already described</p>

TROUBLES	CAUSE	WHAT TO DO
Square cuts not precise	Aluminium fence not adjusted	To adjust the position of hole (A fig.51) proceed as follows <ul style="list-style-type: none"> - unscrew grub screw (A) - turn bush to the right direction - tighten grub screw (E) - carry out a test cut then check the squareness

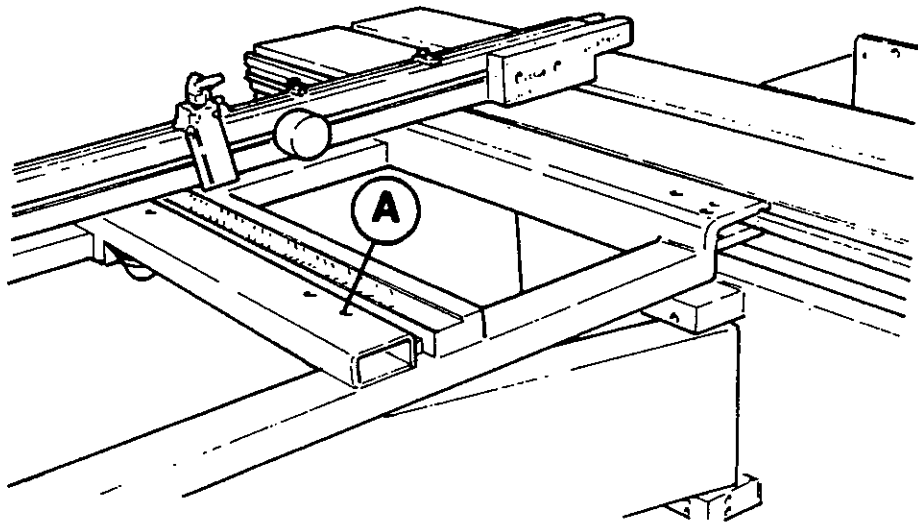

Fig.51

MAINTENANCE

TROUBLE

The scorer doesn't remain in position

CAUSE

The grub screw (L) of cam (H) is loose

The lining pin that is between the grub screw (L) and cam (H) is worn

WHAT TO DO

Remove the cover and by means of a 5 mm socket screw adjust the grub screw (L) so that the cam could rotate in order to regulate the scoring blade position. After the adjustment the grub screw (L) can be tightened so you can be sure that the scorer cannot move

The locking grub screw (B) of scoring pivot (P) is loose

Replace the cam (H) in central position so that you can adjust as much as possible. Replace the scoring pivot so that saw blade and scorer are aligned then tighten the grub screw (B). Carry out a test cut and operating on cam (H) adjust the scoring blade

